

Material Handling Spotlight Standard

Purpose

The purpose of this standard is to define proper usage and minimum performance levels necessary for a material handling spotlight to be effective.

Background

Forklift accidents cause more than 60 deaths and 35,000 serious injuries in the U.S. each year - costing business owners over \$100 million annually. Audible alarms lose their effectiveness over time as workers become used to them and are also less effective in loud environments where they may not be heard. Visual safety devices (such as strobe lights) have been found to be more effective than audible devices, but their effectiveness is severely limited in environments with obstructed views or blind corners. J.W. Speaker Corporation takes workplace safety very seriously, so we pioneered an innovative, new safety device designed to increase visibility and prevent accidents.

The Material Handling Spotlight

J.W. Speaker's material handling spotlights project an intense blue or red light pattern on the ground in front of (or behind) a forklift. This serves as a visual warning to pedestrians and has the benefit of being visible even when the forklift itself is not (ex. around blind corners). J.W. Speaker's material handling spotlights are available in blue or red because studies have shown that they are two of the most noticeable colors to the human eye. The material handling spotlight can be used in conjunction with other audible and visual safety devices, so it is simply an easy add-on to any piece of material handling equipment.

Proper Usage and Minimum Performance Standards

Recommended Color(s): Blue or Red

Recommended Placement: Front and Rear of the vehicle

Recommended Beam Pattern Intensity: 830+ Lux (on the ground)

Recommended Mounting Height: 6' 8" - 8' 4" (2.0m - 2.5m)

Recommended Beam Pattern Distance (from Vehicle): 14' 9" - 17' 11" (4.5m - 5.5m)

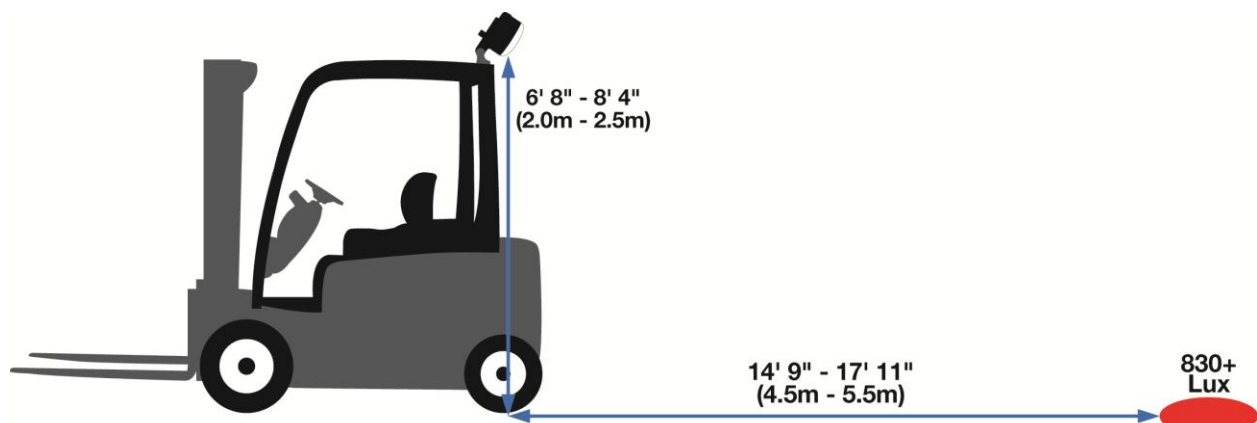

DRIVEN.
TO SEE MORE.