

MODEL 234 FLASH + COLORS

BE SEEN DAY OR NIGHT

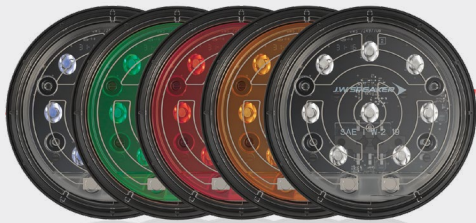

SmartHeat 

HEATED LIGHTING TECHNOLOGY

Huge Impact, Small Light.

J.W. Speaker's Model 234 Flash is not only compact, but offers a wide range of strobe, color, and vehicle fitments to create the best solution for each industry and application.

MODEL
234

Model 234 Flash is available at your authorized J.W. Speaker dealer.
For more information & technical specifications, go to www.jwspeaker.com



J.W. SPEAKER 
Engineered. Lighting. Solutions.

MODEL 234 FLASH + COLORS

BE SAFE, YOUR WAY

Bold and bright, you won't be missed! The Model 234 Flash comes in 5 different SmartHeat® color options: Amber, Blue, Green, Red, and Clear. Available accessories include a rubber mounting grommet, plastic mounting flange and 2 different trim rings to facilitate installation into different types of vehicles.

Safety from all sides. Model 234 Flash provides 3 different flash modes, an exclusive SmartSync™ system to put lamps in simultaneous or alternating flash pattern. 2-in-1 dual function strobe and turn with turn override wire.

As a durable and efficient LED, the Model 234 Flash is guaranteed to provide bright light that commands the attention of drivers behind you, alerting them to your next move. LED lights reach maximum intensity faster than incandescent counterparts, giving drivers more time to react and make necessary adjustments to avoid collisions.

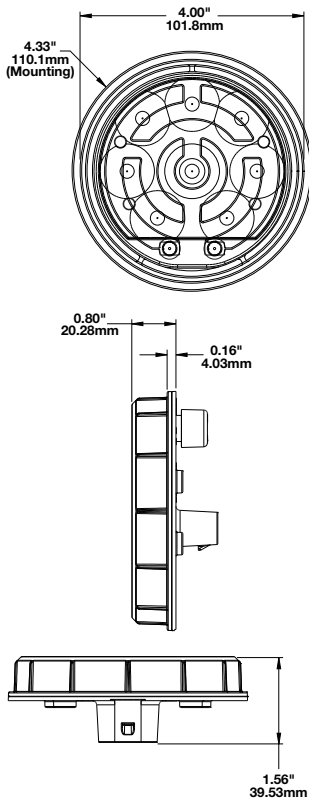

Model 234 FLASH

Heated 4" Round LED Tail Lights, 12-24V DC Input

- 12-24V heated LED signal & strobe lights
- Meets SAE J595 Class II and SAE J588 Strobe standards
- SmartHeat® technology to melt snow & ice
- DOT-compliant for legal on-road use
- Sealed to IP69K for power wash & steam cleaning resistance
- Low power consumption, using only 8W of power to de-ice
- Superior condensation management

Part No.	Description
0642101	12-24V Heated LED Blue Flash Strobe Light
0642111	12-24V Heated LED Green Flash Strobe Light
0642091	12-24V Heated LED Red Flash Strobe Light
0642081	12-24V Heated LED Amber Flash Strobe Light
0642121	12-24V Heated LED Clear Flash Strobe Light

Part No.	Accessories
5747010	6 Pin-DELPHI Connector
4242731	4 Round Rubber Mounting Grommet ¹
8200451	4 Round Chrome Finish Plastic Trim Ring ²
5869401	4 Round Plastic Mounting Flange ³
8200441	4 Round Stainless Steel Trim Ring ⁴

⚠ **WARNING:** Cancer and Reproductive Harm - www.P65Warnings.ca.gov

⚠ **AVERTISSEMENT:** Cancer et effet nocif sur la reproduction - www.P65Warnings.ca.gov

03/03/2020

J.W. Speaker Global Headquarters

N120 W19434 Freistadt Road
PO Box 1011, Germantown, Wisconsin 53022 USA

E-Mail: speaker@jwspeaker.com

J.W. SPEAKER
Engineered. Lighting. Solutions.