

Dual Pedestal Mount Kit for Mosaic

PRODUCT INFORMATION

| | |
|--------------------------------------|------------------------------------|
| Description | Dual Pedestal Mount Kit for Mosaic |
| Height | 97.00 mm / 3.82 in |
| Width | 172.00 mm / 6.77 in |
| Depth | 31.34 mm / 1.23 in |
| Shape | Rectangle |
| Bezel Color | Black |
| Mounting Hardware Description | (x1) 5/16-18 x 1" 5/16-18 X 1 bolt |
| Product Weight | 0.46 lbs / 0.21 kgs |

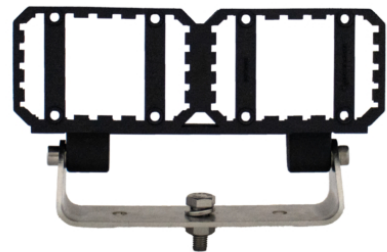

PRODUCT DIMENSIONS

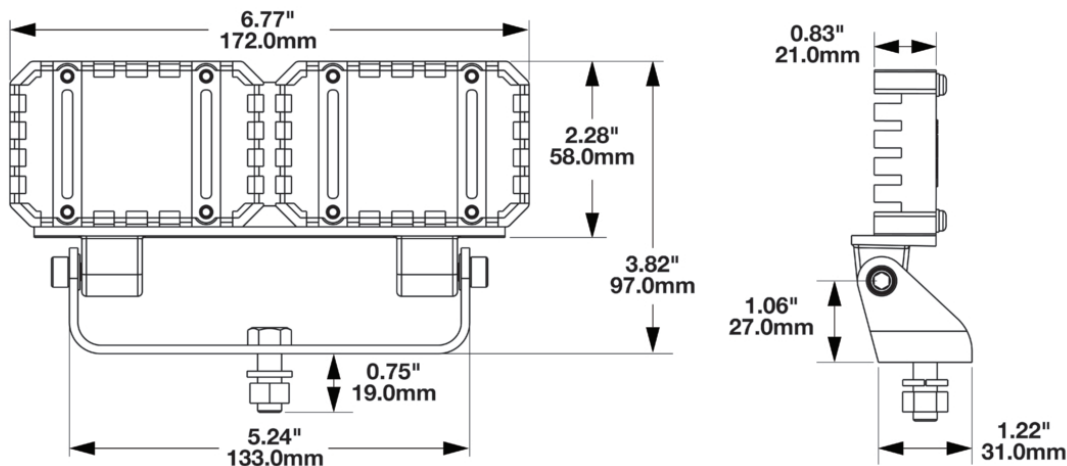

Print date: 2026-06-28

© 2026 J.W. Speaker Corporation • Germantown, WI U.S.A.
 www.jwspeaker.com • speaker@jwspeaker.com • 262.251.6660

J.W. SPEAKER
 Engineered. Lighting. Solutions.

Dual Pedestal Mount Kit for Mosaic

ADDITIONAL INFORMATION

Mounting kit does not include (2) lamps.
Components are not assembled but are provided in a reclosable bag.

Parts included in kit:

8002590 BEZEL 92-DUAL w/INSERT QTY 1
6149970 BRACKET, 6048, SS QTY 1
5651630 WASHER LOCK INT TOOTH 1/4" SS QTY 2
5640620 WASHER, LOCK, HELICAL, 5/16, SS QTY 1
5352410 Screw, #6-32X.5, CR, TX, ST, BZN, AQ QTY 8
5352060 Screw, M6-1X18, CR, SK, SC, SS, RAW QTY 2
5349020 Nut, 5/16-24, FN, SS, RAW QTY 1
5349010 Bolt, 5/16-24X.875, FN, SK, HX, SS, RAW QTY 1
(2) Mounting bolt torque: 80 in-lbs max
(8) Screws to attach lamps to bezel: torque: 14 ± 2 in-lbs
(2) M6 Screws to bracket to bezel: torque: 35 max

PRODUCT WARNINGS

For California residents:

⚠ **WARNING:** Cancer and reproductive harm - www.P65Warnings.ca.gov.

⚠ **AVERTISSEMENT:** Cancer et effet nocif sur la reproduction - www.P65Warnings.ca.gov.

SUITS THESE PRODUCTS

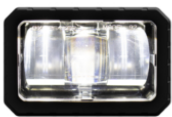

Customizable Modular LED Lights

LED Mosaic Modular
Lighting System -
Model 92

Print date: 2026-06-28

© 2026 J.W. Speaker Corporation • Germantown, WI U.S.A.
www.jwspeaker.com • speaker@jwspeaker.com • 262.251.6660