

Pedestal Mount Kit for Mosaic

PRODUCT INFORMATION

Description	Pedestal Mount Kit for Mosaic
Height	83.57 mm / 3.29 in
Width	84.00 mm / 3.31 in
Depth	33.46 mm / 1.32 in
Shape	Rectangular
Housing Color	Black
Mounting Hardware Description	(x1) 5/16-18 x 1.0" 5/16-18 X 1 bolt
Product Weight	0.17 lbs / 0.08 kgs
Additional Information	Mounting bolt torque: 80 in-lbs max Screw torque: 14 ± 2 in-lbs



PRODUCT DIMENSIONS

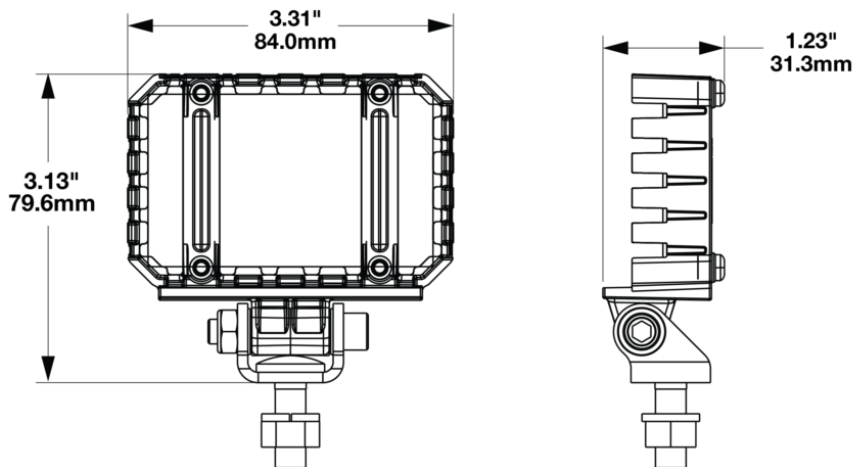

Print date: 2024-11-08

© 2024 J.W. Speaker Corporation • Germantown, WI U.S.A.
www.jwspeaker.com • speaker@jwspeaker.com • 262.251.6660

J.W. SPEAKER
Engineered. Lighting. Solutions.

Pedestal Mount Kit for Mosaic

INSTALLATION & APPLICATION INFORMATION

The 8201031 Pedestal Mounting Hardware Kit should only be used with:

0347971(2)

0558321(2)

0560251(2)

0560121(2)

PRODUCT WARNINGS

For California residents:

⚠ **WARNING:** Cancer and reproductive harm - www.P65Warnings.ca.gov.

⚠ **AVERTISSEMENT:** Cancer et effet nocif sur la reproduction - www.P65Warnings.ca.gov.

SUITS THESE PRODUCTS

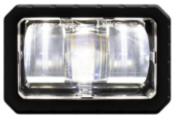

**Customizable
Modular LED Lights**

LED Mosaic Modular
Lighting System -
Model 92

Print date: 2024-11-08

© 2024 J.W. Speaker Corporation • Germantown, WI U.S.A.
www.jwspeaker.com • speaker@jwspeaker.com • 262.251.6660

J.W. SPEAKER 
Engineered. Lighting. Solutions.