

LED Clearance & Marker Lights – Model 173

PRODUCT INFORMATION

Description	12-24V LED Red Vertical Reflex & Marker Lights - Bulk Qty (48 MIN)
Height	114.50 mm / 4.51 in
Width	41.30 mm / 1.63 in
Depth	91.00 mm / 3.58 in
Shape	Rectangular
Outer Lens Material	ACRYLIC
Outer Lens Color	RED
Housing Material	ABS
Housing Color	WHITE
Bezel Color	N/A
Connector or Wiring	Deutsch DTM04-2P
Mating Connector	Deutsch DTM06-2S
Product Weight	0.25 lbs / 0.11 kgs
Shipping Weight	11.75 lbs / 5.33 kgs

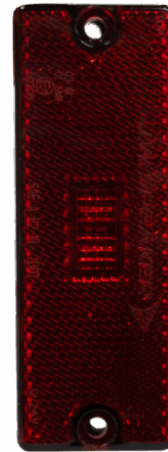

PRODUCT DIMENSIONS

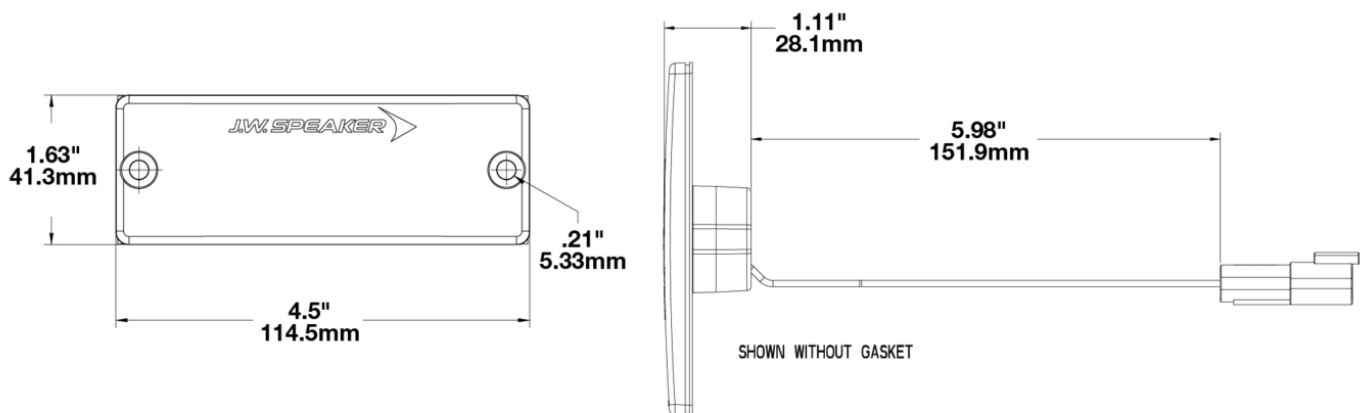

Print date: 2026-06-02

© 2026 J.W. Speaker Corporation • Germantown, WI U.S.A.
 www.jwspeaker.com • speaker@jwspeaker.com • 262.251.6660

J.W. SPEAKER
 Engineered. Lighting. Solutions.

LED Clearance & Marker Lights – Model 173

ELECTRICAL SPECIFICATIONS

Input Voltage	10V-30VV DC
Operating Voltage	12/24VV DC
RED Wire	POWER
BLACK Wire	GROUND

REGULATORY STANDARDS COMPLIANCE



FMVSS 108 s7.4 (Table X)	IEC IP69K
MIL-STD 461	SAE J1113-13
SAE J592	SAE J594

PHOTOMETRIC SPECIFICATIONS

Beam Pattern(s) Signalization - Marker

APPLICATIONS



PRODUCT WARNINGS

For California residents:

⚠ WARNING: Cancer and reproductive harm - www.P65Warnings.ca.gov.

⚠ AVERTISSEMENT: Cancer et effet nocif sur la reproduction - www.P65Warnings.ca.gov.

Print date: 2026-06-02

© 2026 J.W. Speaker Corporation • Germantown, WI U.S.A.
www.jwspeaker.com • speaker@jwspeaker.com • 262.251.6660

J.W. SPEAKER
 Engineered. Lighting. Solutions.

LED Clearance & Marker Lights – Model 173

RELATED PRODUCTS



Part Number
0230852
12-24V LED Amber
Vertical Reflex &
Marker Lights - Bulk
Qty (48 MIN)



Part Number
0230862
12-24V LED Amber
Horizontal Reflex and
Marker Lights - Bulk
Qty (48 MIN)



Part Number
0230892
12-24V LED Red
Horizontal Reflex and
Marker Lights - Bulk
Qty (48 MIN)